

|   |  |     |  |   |
|---|--|-----|--|---|
| 深圳市亿显国际科技有限公司<br>ShenZhen Yes-Display International Technology CO.,LTD. |  |     | 3.5 寸液晶显示屏<br><b>3.5 Inch LCD Display Screen</b> |   |
| File NO.  |  | REV | A/01   | <a href="http://www.yes-display.com">http://www.yes-display.com</a> |

# SPECIFICATION FOR

**Module:YS-T035026(V1.0)**

|             |                |                       |             |
|-------------|----------------|-----------------------|-------------|
| Designed by | R&D Checked by | Quality Department by | Approved by |
|             |                |                       |             |

## Approval by Customer:

OK

NG, Problem survey

Approved By \_\_\_\_\_

File NO.

REV

A/01

<http://www.yes-display.com>

## Revision Record

| REV NO. | REV DATE   | Contents Before Change | Contents After Change | Note |
|---------|------------|------------------------|-----------------------|------|
| V1.0    | 2020/12/21 | NEW ISSUE By Abel;     |                       |      |
| V2.0    | 2022/12/08 | 优化图纸，更新资料              |                       |      |
|         |            |                        |                       |      |
|         |            |                        |                       |      |
|         |            |                        |                       |      |
|         |            |                        |                       |      |
|         |            |                        |                       |      |
|         |            |                        |                       |      |
|         |            |                        |                       |      |
|         |            |                        |                       |      |
|         |            |                        |                       |      |
|         |            |                        |                       |      |
|         |            |                        |                       |      |
|         |            |                        |                       |      |
|         |            |                        |                       |      |
|         |            |                        |                       |      |
|         |            |                        |                       |      |
|         |            |                        |                       |      |

|   |  |     |  |   |
|---|--|-----|--|---|
| 深圳市亿显国际科技有限公司<br>ShenZhen Yes-Display International Technology CO.,LTD. |  |     | 3.5 寸液晶显示屏<br><b>3.5 Inch LCD Display Screen</b> |   |
| File NO.  |  | REV | A/01   | <a href="http://www.yes-display.com">http://www.yes-display.com</a> |

## Contents

| List | Description                               | Page No. |
|------|---|----------|
|      | Cover                                     | 1        |
|      | Revision Record                           | 2        |
|      | Contents                                  | 3        |
| 1    | Technical parameters                      | 4        |
| 2    | Block Dimension                           | 5        |
| 3    | Outline Dimensions                        | 6        |
| 4    | Input terminal Pin Assignment Description | 7        |
| 5    | LCD Optical Characteristics               | 8        |
| 6    | TFT Electrical Characteristics            | 11       |
| 7    | Timing Characteristics                    | 13       |
| 8    | Inspection Standard                       | 16       |
| 9    | Reliability Test Conditions and Methods   | 21       |
| 10   | Cautions and Handling Precautions         | 23       |
| 11   | Packing Method                            | 26       |

|   |  |     |  |   |
|---|--|-----|--|---|
| 深圳市亿显国际科技有限公司<br>ShenZhen Yes-Display International Technology CO.,LTD. |  |     | 3.5 寸液晶显示屏<br><b>3.5 Inch LCD Display Screen</b> |   |
| File NO.  |  | REV | A/01   | <a href="http://www.yes-display.com">http://www.yes-display.com</a> |

## 1. Technical parameters

| ITEM                   | STANDARD VALUES                       | UNITS |
|------------------------|---------------------------------------|-------|
| LCD type               | 3.5TFT                                | --    |
| Dot arrangement        | 320(RGB)×480                          | dots  |
| Color filter array     | RGB vertical stripe                   | --    |
| Display mode           | TN / Transmission / Normally White    | -     |
| Eyes Viewing Direction | 12:00                                 | --    |
| Driver IC              | ST7796U                               | --    |
| Module size            | 54.48(W)×84.71(H)×2.3(T)(Exclude FPC) | mm    |
| Active area            | 48.96(W)×73.44(H)                     | mm    |
| Interface              | 3SPI+18BIT_RGB                        | --    |
| Operating temperature  | -20 ~ +70                             | °C    |
| Storage temperature    | -30 ~ +80                             | °C    |
| Back Light             | White LED*6                           | --    |

## 2. Block Dimension

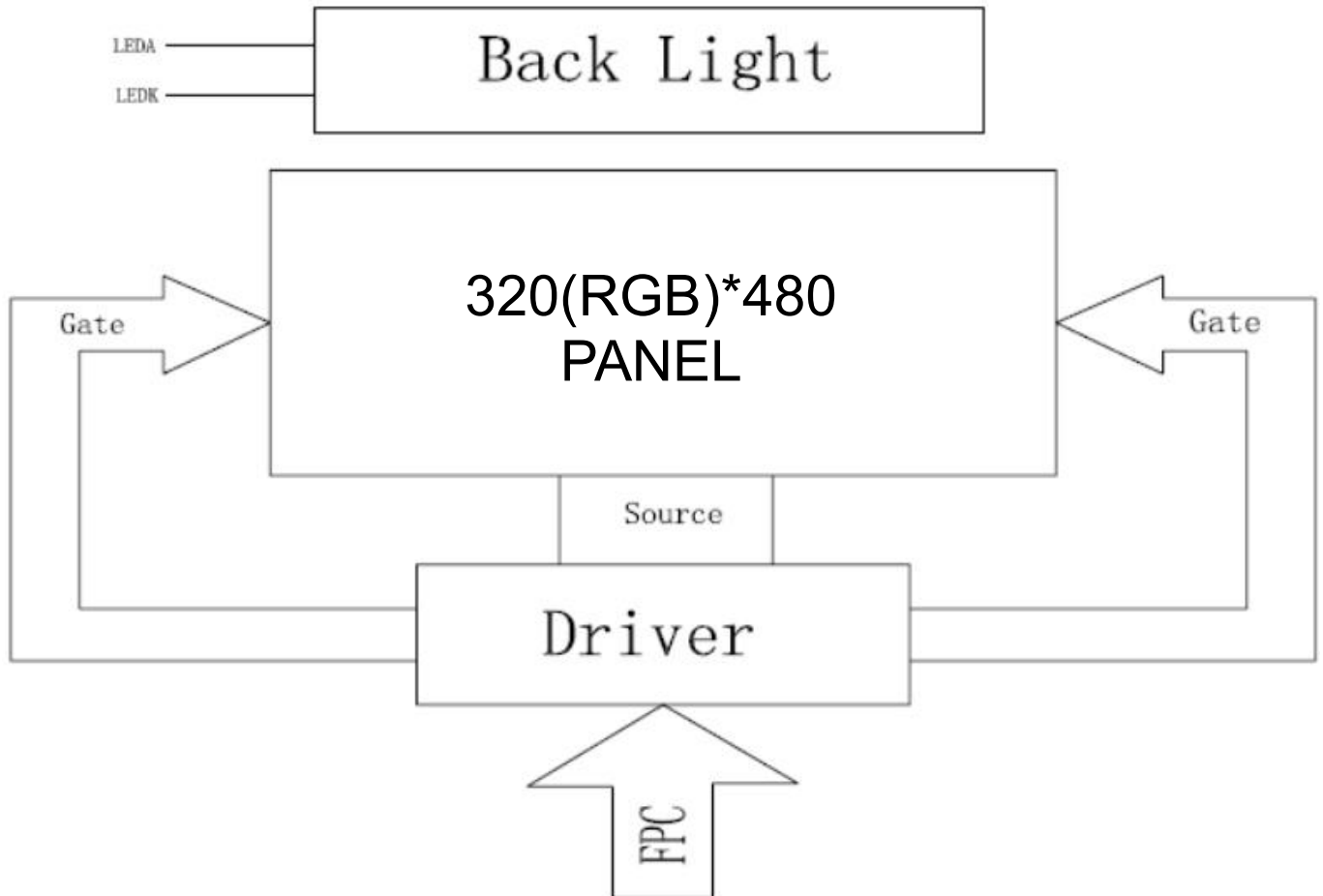

### 3. Outline Dimension

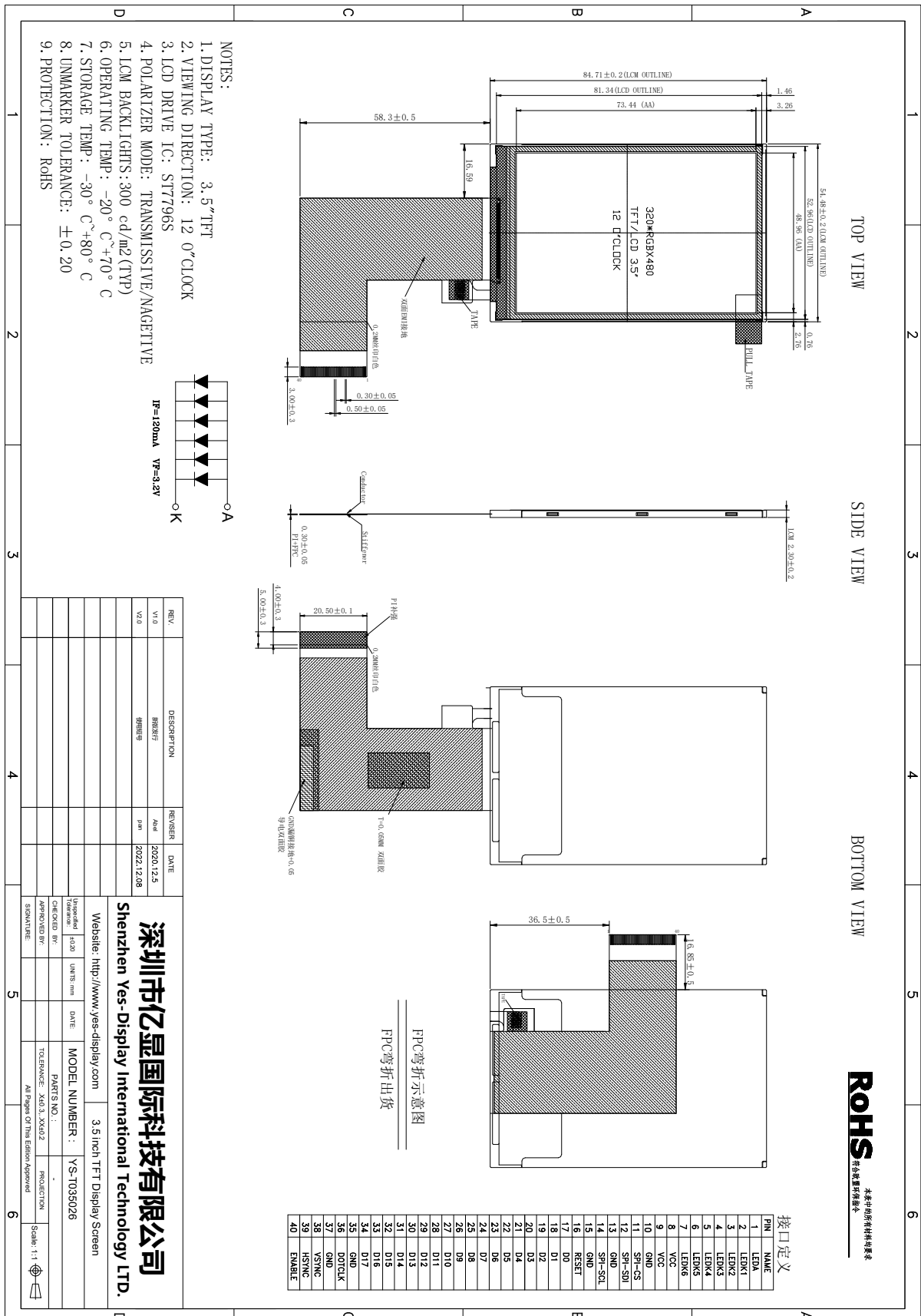

ROHS  
本产品的所有材料均符合  
RoHS指令要求

|   |  |     |  |   |
|---|--|-----|--|---|
| 深圳市亿显国际科技有限公司<br>ShenZhen Yes-Display International Technology CO.,LTD. |  |     | 3.5 寸液晶显示屏<br><b>3.5 Inch LCD Display Screen</b> |   |
| File NO.  |  | REV | A/01   | <a href="http://www.yes-display.com">http://www.yes-display.com</a> |

## 4. Input terminal Pin Assignment Description

### 4.1 LCD Pin Description

| PIN NO. | PIN NAME    | DESCRIPTION   |
|---------|-------------|---|
| 1       | LEDA        | Power supply for backlight cathode input terminal.              |
| 2-7     | LEDK1-LEDK6 | Power supply for backlight anode input terminal.                |
| 8-9     | VCC         | VCC power input   |
| 10      | GND         | Ground for logic.   |
| 11      | SPI-CS      | Chip select input pin ("Low" enable).                           |
| 12      | SPI-SDA     | Serial input signal in SPI I/F.                                 |
| 13      | GND         | Ground for logic.   |
| 14      | SPI-SCL     | This pin is used serial interface clock in SPI                  |
| 15      | GND         | Ground for logic.   |
| 16      | RESET       | Reset signal input terminal, active at 'L'.                     |
| 17-34   | D0-D17      | Data D0-D17 INPUT   |
| 35      | GND         | Ground for logic.   |
| 36      | DCLK        | Dot clock signal input. Latching input data at its rising edge. |
| 37      | GND         | Ground for logic.   |
| 38      | VS          | Vertical sync input. Negative polarity.                         |
| 39      | HS          | Horizontal sync input. Negative polarity.                       |
| 40      | DEN         | Data enable signal for RGB interface operation.                 |

### 4.2 TP Pin Description

**TBD**

## 5. LCD Optical Characteristics

| C. Optical specifications  |        |                    |               |       |       |      |            |
|--|--------|--------------------|---------------|-------|-------|------|------------|
| Item   | Symbol | Condition          | Specification |       |       | Unit | Remark     |
|  |        |                    | Min.          | Typ.  | Max.  |      |            |
| Response time (By Quick)   | Tr+Tf  | $\theta = 0^\circ$ | -             | 20    | 40    | ms   | Note 5     |
| Contrast ratio   | CR     | $\theta = 0^\circ$ | -             | 500   | -     |      | Note 2,6   |
| Viewing angle  | Top    | $CR \geq 10$       | -             | 60    | -     | deg. | Note 2,6,7 |
|  | Bottom | $CR \geq 10$       | -             | 60    | -     |      |            |
|  | Left   | $CR \geq 10$       | -             | 70    | -     |      |            |
|  | Right  | $CR \geq 10$       | -             | 70    | -     |      |            |
| Color chromaticity<br>( CF only with ITO,<br>light source is C<br>light, CIE 1931) | Wx     | $\theta = 0^\circ$ | 0.292         | 0.307 | 0.322 |      | Note 3     |
|  | Wy     |                    | 0.312         | 0.327 | 0.342 |      |            |
|  | Rx     |                    | 0.609         | 0.624 | 0.639 |      |            |
|  | Ry     |                    | 0.316         | 0.331 | 0.346 |      |            |
|  | Gx     |                    | 0.281         | 0.296 | 0.311 |      |            |
|  | Gy     |                    | 0.562         | 0.577 | 0.592 |      |            |
|  | Bx     |                    | 0.128         | 0.143 | 0.158 |      |            |
| By   | 0.094  | 0.109              | 0.124         |       |       |      |            |
| NTSC   |        |                    | 57%           | 60%   | -     |      | Note 3     |
| Cross talk   | Ct     |                    | -             | -     | 2%    |      | Note 9     |
| Transmittance  | Trans  |                    | -             | 5.50% | -     |      | Note 4     |

Note (1) Measurement Setup: The LCD module should be stabilized at given temp. 25°C for 15 minutes to avoid abrupt temperature change during measuring. In order to stabilize the luminance, the measurement should be executed after lighting backlight for 15 minutes in a windless room.

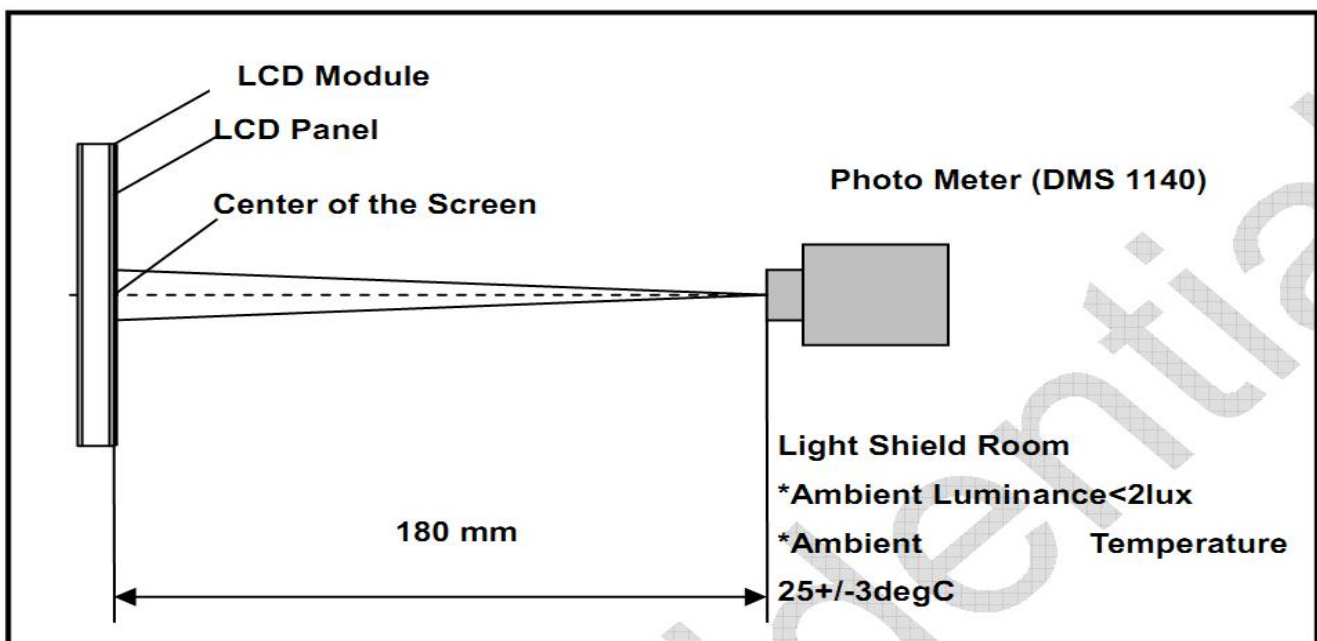

Note (2) Definition of Viewing Angle



|   |  |     |   |   |
|---|--|-----|---|---|
| 深圳市亿显国际科技有限公司<br>ShenZhen Yes-Display International Technology CO.,LTD. |  |     | 3.5 寸液晶显示屏<br>3.5 Inch LCD Display Screen |   |
| File NO.  |  | REV | A/01                                      | <a href="http://www.yes-display.com">http://www.yes-display.com</a> |

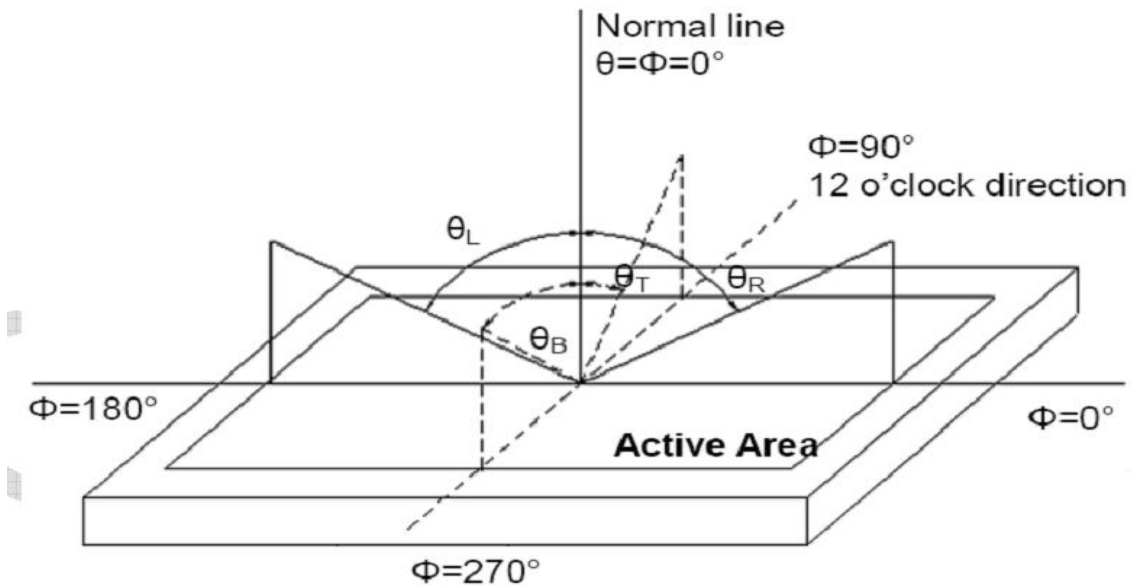

Note (3) Definition of Contrast Ratio (CR)

The contrast ratio can be calculated by the following expression

$$\text{Contrast Ratio (CR)} = L63 / L0$$

L63: Luminance of gray level 63, L0: Luminance of gray level 0

Note (4) Definition of response time

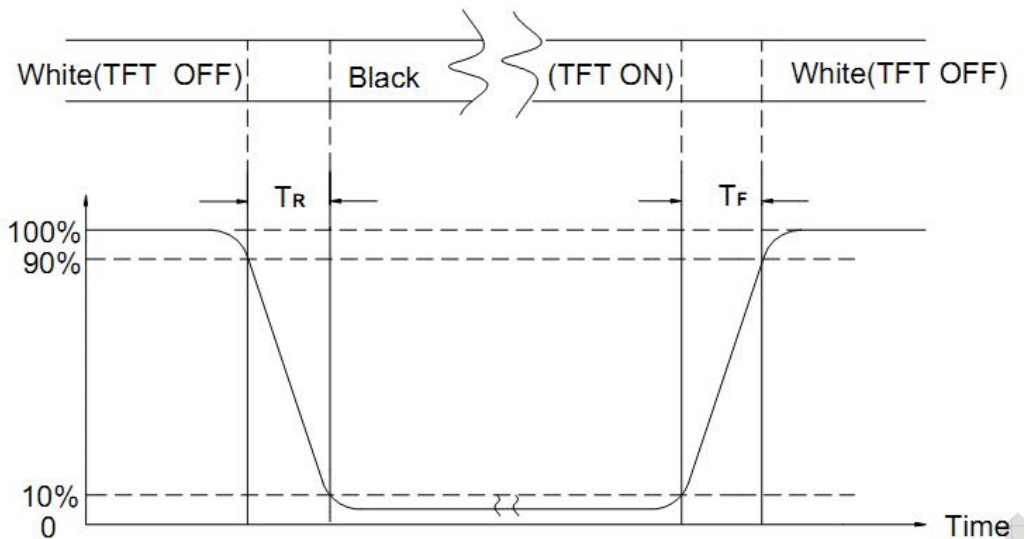

Note (5) Definition of Transmittance (Module is without signal input)

$$\text{Transmittance} = \text{Center Luminance of LCD} / \text{Center Luminance of Back Light} \times 100\%$$

Note (6) Definition of color chromaticity (CIE1931)

Color coordinates measured at the center point of LCD

|   |  |     |   |                            |
|---|--|-----|---|----------------------------|
| 深圳市亿显国际科技有限公司<br>ShenZhen Yes-Display International Technology CO.,LTD. |  |     | 3.5 寸液晶显示屏<br>3.5 Inch LCD Display Screen |                            |
| File NO.  |  | REV | A/01                                      | http://www.yes-display.com |

## 6. TFT Electrical Characteristics

### 6.1 Absolute Maximum Ratings

| Item                  | Symbol | Min. | Max.    | Unit |
|-----------------------|--------|------|---------|------|
| Logic Supply Voltage  | VDD    | -0.3 | 4.0     | V    |
| Input Voltage         | Vin    | -0.3 | VDD+0.3 | V    |
| Operating Temperature | TOP    | -20  | 70      | °C   |
| Storage Temperature   | TST    | -30  | 80      | °C   |
| Storage Humidity      | HD     | 20   | 90      | %RH  |

### 6.2 DC Characteristics

| Item                 | Symbol          | Min.    | Typ. | Max.    | Unit | Remark |
|----------------------|-----------------|---------|------|---------|------|--------|
| Logic Supply Voltage | VDD             | 2.5     | 2.8  | 3.6     | V    | -      |
| Input High Voltage   | V <sub>IH</sub> | 0.7VDD  | -    | VDD     | V    | -      |
| Input Low Voltage    | V <sub>IL</sub> | GND     | -    | 0.3 VDD | V    | -      |
| Output High Voltage  | V <sub>OH</sub> | 0.8 VDD | -    | VDD     | V    | -      |
| Output Low Voltage   | V <sub>OL</sub> | GND     | -    | 0.2 VDD | V    | -      |
| I/O Leak Current     | I <sub>LI</sub> | -1      | -    | 1       | uA   | -      |
| Supply Current       | IDD             | -       | TBD  | -       | mA   | -      |

### 6.3 LED Backlight Characteristics

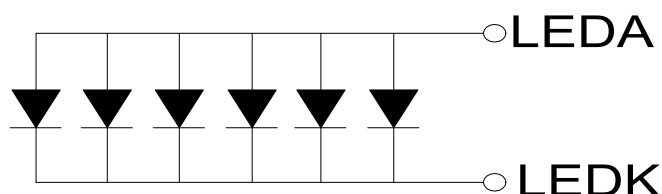

BL CIRCUIT DIAGRAM  
 VF=3.2V, IF=120mA

| Item                       | Symbol | MIN | TYP | MAX | UNIT              | Test Condition |
|----------------------------|--------|-----|-----|-----|-------------------|----------------|
| Supply Voltage             | Vf     | -   | 3.2 | -   | V                 | If=120mA       |
| Supply Current             | If     | -   | 120 | -   | mA                | -              |
| Luminous Intensity for LCM | -      | 250 | 300 | -   | cd/m <sup>2</sup> | If=120mA       |
| Uniformity for LCM         | -      | -   | 60  | -   | %                 | If=120mA       |

|   |  |     |  |   |  |
|---|--|-----|--|---|--|
| 深圳市亿显国际科技有限公司<br>ShenZhen Yes-Display International Technology CO.,LTD. |  |     | 3.5 寸液晶显示屏<br><b>3.5 Inch LCD Display Screen</b> |   |  |
| File NO.  |  | REV | A/01   | <a href="http://www.yes-display.com">http://www.yes-display.com</a> |  |

|                 |       |   |       |   |    |          |
|-----------------|-------|---|-------|---|----|----------|
| Life Time       | -     | - | 50000 | - | Hr | If=120mA |
| Backlight Color | White |   |       |   |    |          |

## 7. Timing Characteristics

### 7.1 TFT Timing Characteristics

#### 7.1.1 Display Serial Interface Timing Characteristics (RGB 8080 system)

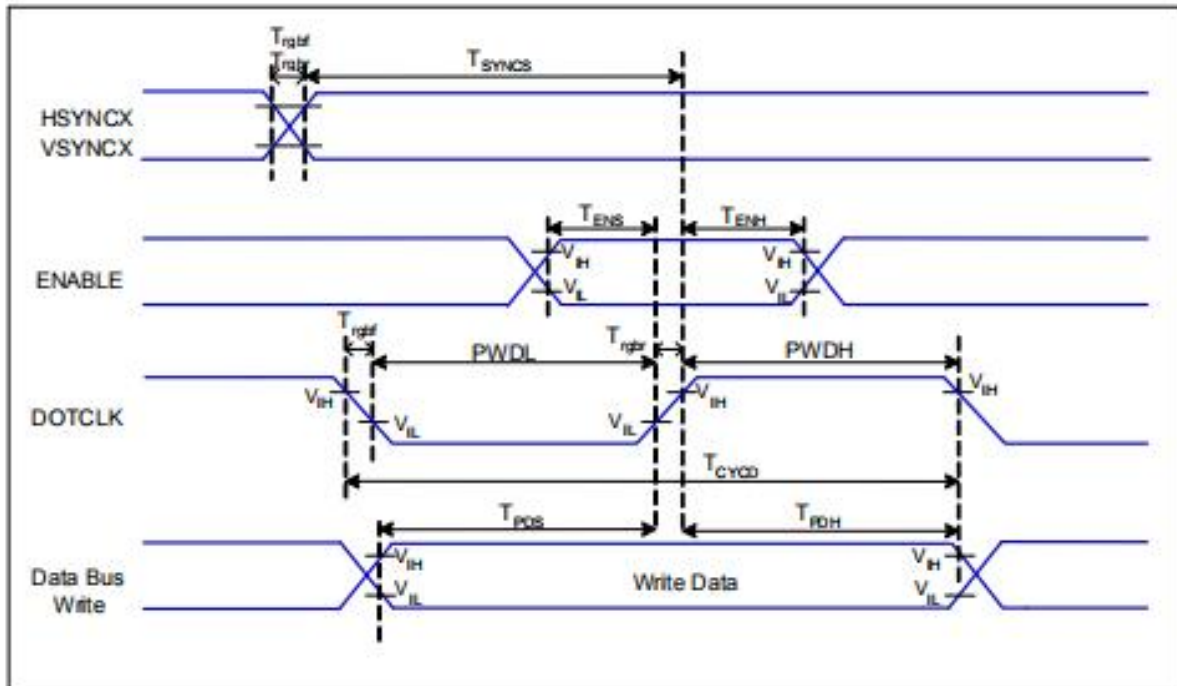

| Signal   | Symbol | Parameter             | Min | Max | Unit | Description  |
|----------|--------|-----------------------|-----|-----|------|--|
| DB[17:0] | TDST   | Data Setup Time       | 20  | --  | ns   | TRAT, TRATFM: 3K ohm Pull up or Down and 30pF Parallel Cap. To GND.<br>TODH: 3K ohm Pull up or Down. |
|          | TDHT   | Data Hold Time        | 10  | --  | ns   |  |
|          | TRAT   | Read Access Time (ID) | --  | 150 | ns   |  |
|          | TODH   | Output Disable Time   | 10  | --  | ns   |  |

Table 3 8080 Parallel Interface Characteristics

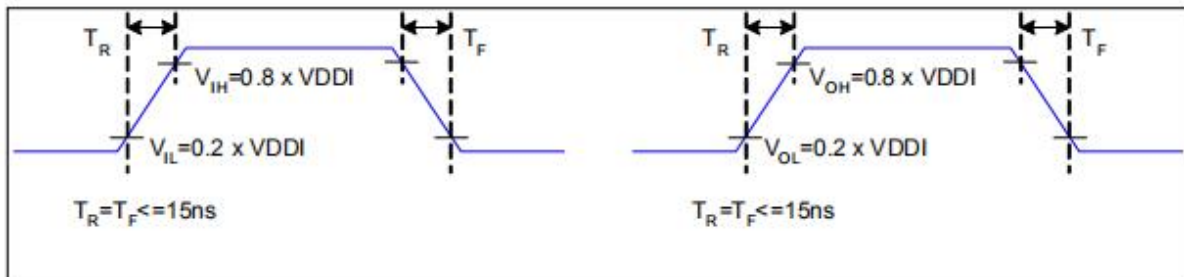
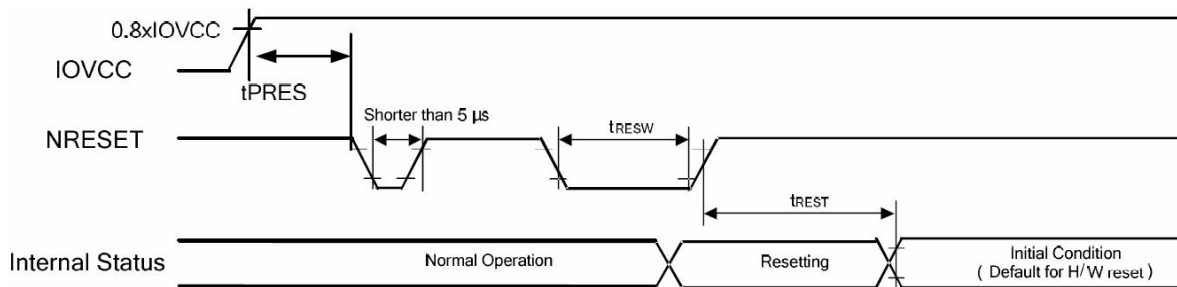

Figure 3 Rising and Falling Timing for I/O Signal

Note: The rising time and falling time ( $T_r$ ,  $T_f$ ) of input signal and fall time are specified at 15 ns or less. Logic high and low levels are specified as 20% and 80% of VDDI for Input signals.

### 7.1.2 Reset Timing Characteristics



### 7.1.3 Power on/off timing sequence check the IC datasheet!

### 7.2 TP Timing Characteristics

TBD

|   |  |     |  |   |
|---|--|-----|--|---|
| 深圳市亿显国际科技有限公司<br>ShenZhen Yes-Display International Technology CO.,LTD. |  |     | 3.5 寸液晶显示屏<br><b>3.5 Inch LCD Display Screen</b> |   |
| File NO.  |  | REV | A/01   | <a href="http://www.yes-display.com">http://www.yes-display.com</a> |

## 8. Inspection Standard

### 8.1 Incoming Inspection and Standard:

The below incoming inspection are applied to the TFT LCM Modules supplied by ShenZhen Yes-Display International Technology CO.,LTD. The customers should inspect the LCM within 14 days after receiving the goods. The result of inspection should be notified to the Seller in the writing copy promptly, if the customer do not send them within 14 days, the seller has the right to judge as acceptance of goods. The inspection lot size is treated as the quantity per shipment and per model. The sampling plan shall be inspected under MIL-STD015E in Level II by single sampling. The acceptable quality level (AQL) are categorized as below grades:

CRITICAL= 0.4%, MAJOR= 0.65%, MINOR= 1.5%

### 8.2 Inspection condition and Warranty policy:

The delivered LCM should be stored properly, ideally under climate-controlled environment at 25 ( $\pm 5$ ) degree Celsius as well as 60% ( $\pm 10$ ) Relative Humidity. The LCM shall be inspected in the viewing angle of 45 degree from the four major angles (U/D/L/R) under the single fluorescent lamp of 20W (equal to 300 to 500 lux). For warranty, ShenZhen Yes-Display International Technology CO.,LTD. will provide 12 months of warranty period as standard, and provide the new replacement for the defective products which belong to the Seller's responsibility verified by the quality department.

|   |  |     |  |   |
|---|--|-----|--|---|
| 深圳市亿显国际科技有限公司<br>ShenZhen Yes-Display International Technology CO.,LTD. |  |     | 3.5 寸液晶显示屏<br><b>3.5 Inch LCD Display Screen</b> |   |
| File NO.  |  | REV | A/01   | <a href="http://www.yes-display.com">http://www.yes-display.com</a> |

### 8.3 Inspection Criteria:

#### 8.3.1 Critical defect

| Item No. | Inspection content | Judgement  |
|----------|--------------------|--|
| 8.3.1.1  | Functional defects | No display, abnormal display, short circuit, missing line, off-contrast and chromaticity, Touch Panel non-function |
| 8.3.1.2  | Model mixed        | Other model mixed  |

#### 8.3.2 Major defect:

| Item No. | Inspection content | Judgement  |
|----------|--------------------|--|
| 8.3.2.1  | Product indication | Missing model no. and wrong model no. is indicated on the LCM. |
| 8.3.2.2  | Glass cracking     | The LCD and touch panel glass crack or breakage                |
| 8.3.2.3  | Missing component  | The function component missing such as connector, cable, etc.  |

#### 8.3.3 Minor defect (LCD) :

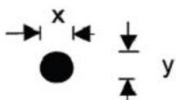
| Item No.               | Inspection content  | Judgement   |               |                 |                 |        |                        |                  |               |                      |   |  |            |                |
|------------------------|---|---|---------------|-----------------|-----------------|--------|------------------------|------------------|---------------|----------------------|---|--|------------|----------------|
| 8.3.3.1                | Black/White spot<br>Foreign particles<br>Dust in the cell | $\phi = (x+y) / 2$  <table border="1"> <thead> <tr> <th>Diameter (mm)</th> <th>Acceptable Q'ty</th> </tr> </thead> <tbody> <tr> <td><math>\Phi \leq 0.1</math></td> <td>Ignore</td> </tr> <tr> <td><math>0.1 &lt; \Phi \leq 0.25</math></td> <td>3 (Distance&gt;5mm)</td> </tr> <tr> <td><math>0.25 &lt; \Phi</math></td> <td>Not allowed</td> </tr> </tbody> </table> | Diameter (mm) | Acceptable Q'ty | $\Phi \leq 0.1$ | Ignore | $0.1 < \Phi \leq 0.25$ | 3 (Distance>5mm) | $0.25 < \Phi$ | Not allowed          |   |  |            |                |
| Diameter (mm)          | Acceptable Q'ty   |   |               |                 |                 |        |                        |                  |               |                      |   |  |            |                |
| $\Phi \leq 0.1$        | Ignore  |   |               |                 |                 |        |                        |                  |               |                      |   |  |            |                |
| $0.1 < \Phi \leq 0.25$ | 3 (Distance>5mm)  |   |               |                 |                 |        |                        |                  |               |                      |   |  |            |                |
| $0.25 < \Phi$          | Not allowed   |   |               |                 |                 |        |                        |                  |               |                      |   |  |            |                |
| 8.3.3.2                | Linear defect<br>Black/white line<br>Black/white scratch  | <table border="1"> <thead> <tr> <th>Length(mm)</th> <th>Width (mm)</th> <th>Acceptable Q'ty</th> </tr> </thead> <tbody> <tr> <td></td> <td><math>W \leq 0.03</math></td> <td>Ignore</td> </tr> <tr> <td><math>L \leq 5.0</math></td> <td><math>0.03 &lt; W \leq 0.07</math></td> <td>3</td> </tr> <tr> <td></td> <td><math>0.07 &lt; W</math></td> <td>Follow 8.3.3.1</td> </tr> </tbody> </table>  | Length(mm)    | Width (mm)      | Acceptable Q'ty |        | $W \leq 0.03$          | Ignore           | $L \leq 5.0$  | $0.03 < W \leq 0.07$ | 3 |  | $0.07 < W$ | Follow 8.3.3.1 |
| Length(mm)             | Width (mm)  | Acceptable Q'ty   |               |                 |                 |        |                        |                  |               |                      |   |  |            |                |
|                        | $W \leq 0.03$   | Ignore  |               |                 |                 |        |                        |                  |               |                      |   |  |            |                |
| $L \leq 5.0$           | $0.03 < W \leq 0.07$                                      | 3   |               |                 |                 |        |                        |                  |               |                      |   |  |            |                |
|                        | $0.07 < W$  | Follow 8.3.3.1  |               |                 |                 |        |                        |                  |               |                      |   |  |            |                |

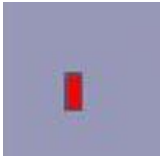
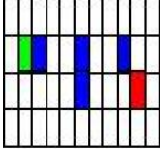
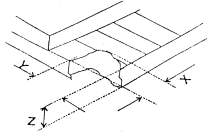
| 8.3.3.3  | Polarizer Bubbles<br>Dent on polarizer | <table border="1"> <thead> <tr> <th>Diameter (mm)</th> <th>Acceptable Q'ty</th> </tr> </thead> <tbody> <tr> <td><math>\Phi \leq 0.2</math></td> <td>Ignore</td> </tr> <tr> <td><math>0.2 &lt; \Phi \leq 0.5</math></td> <td>2 (Distance&gt;5mm)</td> </tr> <tr> <td><math>0.5 &lt; \Phi</math></td> <td>Not allowed</td> </tr> </tbody> </table>  | Diameter (mm) | Acceptable Q'ty | $\Phi \leq 0.2$  | Ignore                     | $0.2 < \Phi \leq 0.5$ | 2 (Distance>5mm)           | $0.5 < \Phi$ | Not allowed |
|--|--|---|---------------|-----------------|--|----------------------------|-----------------------|----------------------------|--------------|-------------|
| Diameter (mm)  | Acceptable Q'ty                        |   |               |                 |  |                            |                       |                            |              |             |
| $\Phi \leq 0.2$  | Ignore                                 |   |               |                 |  |                            |                       |                            |              |             |
| $0.2 < \Phi \leq 0.5$  | 2 (Distance>5mm)                       |   |               |                 |  |                            |                       |                            |              |             |
| $0.5 < \Phi$   | Not allowed                            |   |               |                 |  |                            |                       |                            |              |             |
| 8.3.3.4  | Electrical Defect<br>Dot               | <p>Bright dot and Dark dot definition:</p>  <p>or</p>  <p>(Two adjacent dot)</p> <p>Inspection pattern: black, white, red, green, and blue screen.</p> <table border="1"> <thead> <tr> <th>Items</th> <th>Acceptable Q'ty</th> </tr> </thead> <tbody> <tr> <td>Bright dot</td> <td><math>N \leq 4</math> (Distance &gt;5mm)</td> </tr> <tr> <td>Dark dot</td> <td><math>N \leq 4</math> (Distance &gt;5mm)</td> </tr> </tbody> </table> | Items         | Acceptable Q'ty | Bright dot   | $N \leq 4$ (Distance >5mm) | Dark dot              | $N \leq 4$ (Distance >5mm) |              |             |
| Items  | Acceptable Q'ty                        |   |               |                 |  |                            |                       |                            |              |             |
| Bright dot   | $N \leq 4$ (Distance >5mm)             |   |               |                 |  |                            |                       |                            |              |             |
| Dark dot   | $N \leq 4$ (Distance >5mm)             |   |               |                 |  |                            |                       |                            |              |             |
| 8.3.3.5  | Glass Defect-<br>Corner chipping       |  <table border="1"> <thead> <tr> <th>Size(mm)</th> <th>Judgement</th> </tr> </thead> <tbody> <tr> <td><math>X \leq 3\text{mm}, Y \leq S,</math><br/><math>Z \leq T</math><br/>(S= ITO length,<br/>T=Single glass thickness)</td> <td>Accept</td> </tr> </tbody> </table>   | Size(mm)      | Judgement       | $X \leq 3\text{mm}, Y \leq S,$<br>$Z \leq T$<br>(S= ITO length,<br>T=Single glass thickness) | Accept                     |                       |                            |              |             |
| Size(mm)   | Judgement                              |   |               |                 |  |                            |                       |                            |              |             |
| $X \leq 3\text{mm}, Y \leq S,$<br>$Z \leq T$<br>(S= ITO length,<br>T=Single glass thickness) | Accept                                 |   |               |                 |  |                            |                       |                            |              |             |



8.3.3.6

**Glass Defect-  
Side fragment**

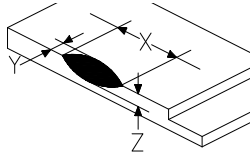

| Size(mm)   | Judgement |
|--|-----------|
| $X \leq 2$ mm, $Y \leq$ border edge<br>$Z \leq T$<br>(T= single glass thickness) | Accept    |

8.3.4 Minor defect (Touch Panel)

| Item No.                                     | Inspection content   | Judgement   |               |                 |                                  |        |  |   |                  |        |
|--|--|---|---------------|-----------------|----------------------------------|--------|--|---|------------------|--------|
| 8.3.4.1                                      | Scratch, dust, particles, foreign materials in "linear type" | <table border="1"> <thead> <tr> <th>Size (mm)</th> <th>Acceptable Q'ty</th> </tr> </thead> <tbody> <tr> <td><math>W \leq 0.05</math>mm, <math>L \leq 10</math>mm</td> <td>Ignore</td> </tr> <tr> <td><math>0.05</math>mm &lt; <math>W \leq 0.07</math>mm, <math>L \leq 10</math>mm</td> <td>3</td> </tr> <tr> <td><math>W &gt; 0.07</math>mm</td> <td>Reject</td> </tr> </tbody> </table> | Size (mm)     | Acceptable Q'ty | $W \leq 0.05$ mm, $L \leq 10$ mm | Ignore | $0.05$ mm < $W \leq 0.07$ mm, $L \leq 10$ mm | 3 | $W > 0.07$ mm    | Reject |
| Size (mm)                                    | Acceptable Q'ty  |   |               |                 |                                  |        |  |   |                  |        |
| $W \leq 0.05$ mm, $L \leq 10$ mm             | Ignore   |   |               |                 |                                  |        |  |   |                  |        |
| $0.05$ mm < $W \leq 0.07$ mm, $L \leq 10$ mm | 3  |   |               |                 |                                  |        |  |   |                  |        |
| $W > 0.07$ mm                                | Reject   |   |               |                 |                                  |        |  |   |                  |        |
| 8.3.4.2                                      | Scratch, dust, particles, foreign materials in "round type"  | <table border="1"> <thead> <tr> <th>Diameter (mm)</th> <th>Acceptable Q'ty</th> </tr> </thead> <tbody> <tr> <td><math>\Phi \leq 0.25</math>mm</td> <td>Ignore</td> </tr> <tr> <td><math>0.25</math>mm &lt; <math>\Phi \leq 0.35</math>mm</td> <td>5</td> </tr> <tr> <td><math>\Phi &gt; 0.35</math>mm</td> <td>Reject</td> </tr> </tbody> </table>  | Diameter (mm) | Acceptable Q'ty | $\Phi \leq 0.25$ mm              | Ignore | $0.25$ mm < $\Phi \leq 0.35$ mm              | 5 | $\Phi > 0.35$ mm | Reject |
| Diameter (mm)                                | Acceptable Q'ty  |   |               |                 |                                  |        |  |   |                  |        |
| $\Phi \leq 0.25$ mm                          | Ignore   |   |               |                 |                                  |        |  |   |                  |        |
| $0.25$ mm < $\Phi \leq 0.35$ mm              | 5  |   |               |                 |                                  |        |  |   |                  |        |
| $\Phi > 0.35$ mm                             | Reject   |   |               |                 |                                  |        |  |   |                  |        |
| 8.3.4.3                                      | Air bubbles  | <table border="1"> <thead> <tr> <th>Diameter (mm)</th> <th>Acceptable Q'ty</th> </tr> </thead> <tbody> <tr> <td><math>\Phi \leq 0.2</math>mm</td> <td>Ignore</td> </tr> <tr> <td><math>0.2</math>mm &lt; <math>\Phi \leq 0.5</math>mm</td> <td>3</td> </tr> <tr> <td><math>\Phi &gt; 0.5</math>mm</td> <td>Reject</td> </tr> </tbody> </table>  | Diameter (mm) | Acceptable Q'ty | $\Phi \leq 0.2$ mm               | Ignore | $0.2$ mm < $\Phi \leq 0.5$ mm                | 3 | $\Phi > 0.5$ mm  | Reject |
| Diameter (mm)                                | Acceptable Q'ty  |   |               |                 |                                  |        |  |   |                  |        |
| $\Phi \leq 0.2$ mm                           | Ignore   |   |               |                 |                                  |        |  |   |                  |        |
| $0.2$ mm < $\Phi \leq 0.5$ mm                | 3  |   |               |                 |                                  |        |  |   |                  |        |
| $\Phi > 0.5$ mm                              | Reject   |   |               |                 |                                  |        |  |   |                  |        |

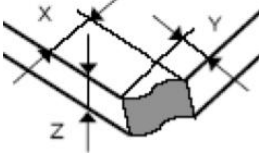
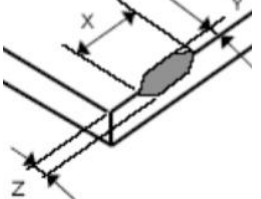
| 8.3.4.5   | Scratch on printing area | <table border="1"> <thead> <tr> <th>Size (mm)</th> <th>Acceptable Q'ty</th> </tr> </thead> <tbody> <tr> <td><math>W \leq 0.03\text{mm}, L \leq 5\text{ mm}</math></td> <td>Ignore</td> </tr> <tr> <td><math>0.03\text{mm} &lt; W \leq 0.05\text{mm}, L \leq 5\text{mm}</math></td> <td>3</td> </tr> <tr> <td><math>W &gt; 0.05\text{mm}</math> or <math>L &gt; 5\text{mm}</math></td> <td>Reject</td> </tr> </tbody> </table> | Size (mm) | Acceptable Q'ty | $W \leq 0.03\text{mm}, L \leq 5\text{ mm}$  | Ignore | $0.03\text{mm} < W \leq 0.05\text{mm}, L \leq 5\text{mm}$ | 3 | $W > 0.05\text{mm}$ or $L > 5\text{mm}$ | Reject |
|---|--------------------------|---|-----------|-----------------|---|--------|---|---|---|--------|
| Size (mm)   | Acceptable Q'ty          |   |           |                 |   |        |   |   |   |        |
| $W \leq 0.03\text{mm}, L \leq 5\text{ mm}$  | Ignore                   |   |           |                 |   |        |   |   |   |        |
| $0.03\text{mm} < W \leq 0.05\text{mm}, L \leq 5\text{mm}$                                 | 3                        |   |           |                 |   |        |   |   |   |        |
| $W > 0.05\text{mm}$ or $L > 5\text{mm}$   | Reject                   |   |           |                 |   |        |   |   |   |        |
| 8.3.4.6   | Corner chipping          |  <table border="1"> <thead> <tr> <th>Size(mm)</th> <th>Judgement</th> </tr> </thead> <tbody> <tr> <td><math>X \leq 2\text{mm}, Y \leq 2\text{mm}</math><br/><math>Z &lt; 1/2T</math><br/>(T= single glass thickness)</td> <td>Accept</td> </tr> </tbody> </table>  | Size(mm)  | Judgement       | $X \leq 2\text{mm}, Y \leq 2\text{mm}$<br>$Z < 1/2T$<br>(T= single glass thickness)       | Accept |   |   |   |        |
| Size(mm)  | Judgement                |   |           |                 |   |        |   |   |   |        |
| $X \leq 2\text{mm}, Y \leq 2\text{mm}$<br>$Z < 1/2T$<br>(T= single glass thickness)       | Accept                   |   |           |                 |   |        |   |   |   |        |
| 8.3.4.7   | Edge chipping            |  <table border="1"> <thead> <tr> <th>Size(mm)</th> <th>Judgement</th> </tr> </thead> <tbody> <tr> <td><math>X \leq 3\text{ mm}, Y \leq 3\text{ mm}</math><br/><math>Z \leq 1/2 T</math><br/>(T= single glass thickness)</td> <td>Accept</td> </tr> </tbody> </table>  | Size(mm)  | Judgement       | $X \leq 3\text{ mm}, Y \leq 3\text{ mm}$<br>$Z \leq 1/2 T$<br>(T= single glass thickness) | Accept |   |   |   |        |
| Size(mm)  | Judgement                |   |           |                 |   |        |   |   |   |        |
| $X \leq 3\text{ mm}, Y \leq 3\text{ mm}$<br>$Z \leq 1/2 T$<br>(T= single glass thickness) | Accept                   |   |           |                 |   |        |   |   |   |        |

## 9. Reliability Test Conditions and Methods

### 9.1 Reliability Test Conditions and Methods:

| NO. | TEST ITEMS                 | TEST CONDITION   | INSPECTION AFTER TEST   |
|-----|----------------------------|--|---|
| ①   | High Temperature Storage   | 80°C±2°C×96Hours   | Inspection after 2~4hours storage at room temperature, the samples should be free from defects:<br>1, Air bubble in the LCD.<br>2, Seal leak.<br>3, Non-display.<br>4, Missing segments.<br>5, Glass crack.<br>6, Current IDD is twice higher than initial value.<br>7, The surface shall be free from damage.<br>8, The electric characteristic requirements shall be satisfied. |
| ②   | Low Temperature Storage    | -30°C±2°C×96Hours  |   |
| ③   | High Temperature Operating | 70°C±2°C×96Hours   |   |
| ④   | Low Temperature Operating  | -20°C±2°C×96Hours  |   |
| ⑤   | Temperature Cycle(Storage) | -20°C ↔ 25°C ↔ 70°C<br>(30min) ← (5min) → (30min)<br>1cycle<br>Total 10cycle   |   |
| ⑥   | Damp Proof Test (Storage)  | 50°C±5°C×90%RH×96Hours   |   |
| ⑦   | Vibration Test             | Frequency:10Hz~55Hz~10Hz<br>Amplitude:1.5MM<br>X,Y,Z direction for total 3hours<br>(packing condition test will be tested by a carton) |   |

File NO.

REV

A/01

<http://www.yes-display.com>

|   |               |  |  |
|---|---------------|--|--|
| ⑧ | Drooping Test | Drop to the ground from 1M height<br>one time<br>every side of carton.<br>(packing condition test will be<br>tested by a carton) |  |
| ⑨ | ESD Test      | Voltage:±8KV,R:330Ω,C:150PF,Ai<br>r Mode,10times   |  |

REMARK:

- 1, The Test samples should be applied to only one test item.
- 2, Sample side for each test item is 5~10pcs.
- 3,For Damp Proof Test, Pure water(Resistance>10MΩ)should be used.
- 4,In case of malfunction defect caused by ESD damage, if it would be recovered to normal state after resetting, it would be judge as a good part.
- 5, EL evaluation should be accepted from reliability test with humidity and temperature: Some defects such as black spot/blemish can happen by natural chemical reaction with humidity and Fluorescence EL has.
- 6, Failure Judgment Criterion: Basic Specification Electrical Characteristic, Mechanical Characteristic, Optical Characteristic.

|   |  |     |  |   |
|---|--|-----|--|---|
| 深圳市亿显国际科技有限公司<br>ShenZhen Yes-Display International Technology CO.,LTD. |  |     | 3.5 寸液晶显示屏<br><b>3.5 Inch LCD Display Screen</b> |   |
| File NO.  |  | REV | A/01   | <a href="http://www.yes-display.com">http://www.yes-display.com</a> |

## 10. Cautions and Handling Precautions

### 10.1 Mounting method

The LCD panel of TFT module consists of two thin glass plates with polarizes which easily be damaged. And since the module in so constructed as to be fixed by utilizing fitting holes in the printed circuit board.

Extreme care should be needed when handling the LCD modules.

### 10.2 Caution of LCD handling and cleaning

When cleaning the display surface, Use soft cloth with solvent

[Recommended below] and wipe lightly

- Isopropyl alcohol
- Ethyl alcohol

Do not wipe the display surface with dry or hard materials that will damage the polarizer surface.

Do not use the following solvent:

- Water
- Aromatics

Do not wipe ITO pad area with the dry or hard materials that will damage the ITO patterns

Do not use the following solvent on the pad or prevent it from being contaminated:

- Soldering flux
- Chlorine (Cl) , Sulfur (S)

If goods were sent without being silicon coated on the pad, ITO patterns could be damaged due to the corrosion as time goes on.

If ITO corrosion happen by miss-handling or using some materials such as Chlorine (Cl), Sulfur (S) from customer, Responsibility is on customer.

|   |  |     |  |   |
|---|--|-----|--|---|
| 深圳市亿显国际科技有限公司<br>ShenZhen Yes-Display International Technology CO.,LTD. |  |     | 3.5 寸液晶显示屏<br><b>3.5 Inch LCD Display Screen</b> |   |
| File NO.  |  | REV | A/01   | <a href="http://www.yes-display.com">http://www.yes-display.com</a> |

### 10.3 Caution against static charge

The LCD module use C-MOS LSI drivers, so we recommended that you:

Connect any unused input terminal to power or ground, do not input any signals before power is turned on, and ground your body, work/assembly areas, and assembly equipment to protect against static electricity.

### 10.4 packing

- Module employs LCD elements and must be treated as such.
- Avoid intense shock and falls from a height.
- To prevent modules from degradation, do not operate or store them exposed direct to sunshine or high temperature/humidity

### 10.5 Caution for operation

- It is an indispensable condition to drive LCD's within the specified voltage limit since the higher voltage then the limit cause the shorter LCD life.
- An electrochemical reaction due to direct current causes LCD's undesirable deterioration, so that the use of direct current drive should be avoided.
- Response time will be extremely delayed at lower temperature then the operating temperature range and on the other hand at higher temperature LCD's how dark color in them. However those phenomena do not mean malfunction or out of order with LCD's, which will come back in the specified operation temperature.
- If the display area is pushed hard during operation, some font will be abnormally displayed but it resumes normal condition after turning off once.
- Slight dew depositing on terminals is a cause for electro-chemical reaction resulting in terminal open circuit.

Usage under the maximum operating temperature, 50%Rh or less is required.

### 10.6 storing

In the case of storing for a long period of time for instance, for years for the purpose or replacement use, the following ways are recommended.

- Storage in a polyethylene bag with the opening sealed so as not to enter fresh air outside in it. And with no desiccant.
- Placing in a dark place where neither exposure to direct sunlight nor light's keeping the storage temperature range.
- Storing with no touch on polarizer surface by the anything else.

[It is recommended to store them as they have been contained in the inner container at

|   |  |     |   |   |
|---|--|-----|---|---|
| 深圳市亿显国际科技有限公司<br>ShenZhen Yes-Display International Technology CO.,LTD. |  |     | 3.5 寸液晶显示屏<br>3.5 Inch LCD Display Screen |   |
| File NO.  |  | REV | A/01                                      | <a href="http://www.yes-display.com">http://www.yes-display.com</a> |

the time of delivery from us

## 10.7 Safety

- It is recommendable to crash damaged or unnecessary LCD's into pieces and wash off liquid crystal by either of solvents such as acetone and ethanol, which should be burned up later.
- When any liquid leaked out of a damaged glass cell comes in contact with your hands, please wash it off well with soap and water

## 11. Packing Method

### 11.1 Method

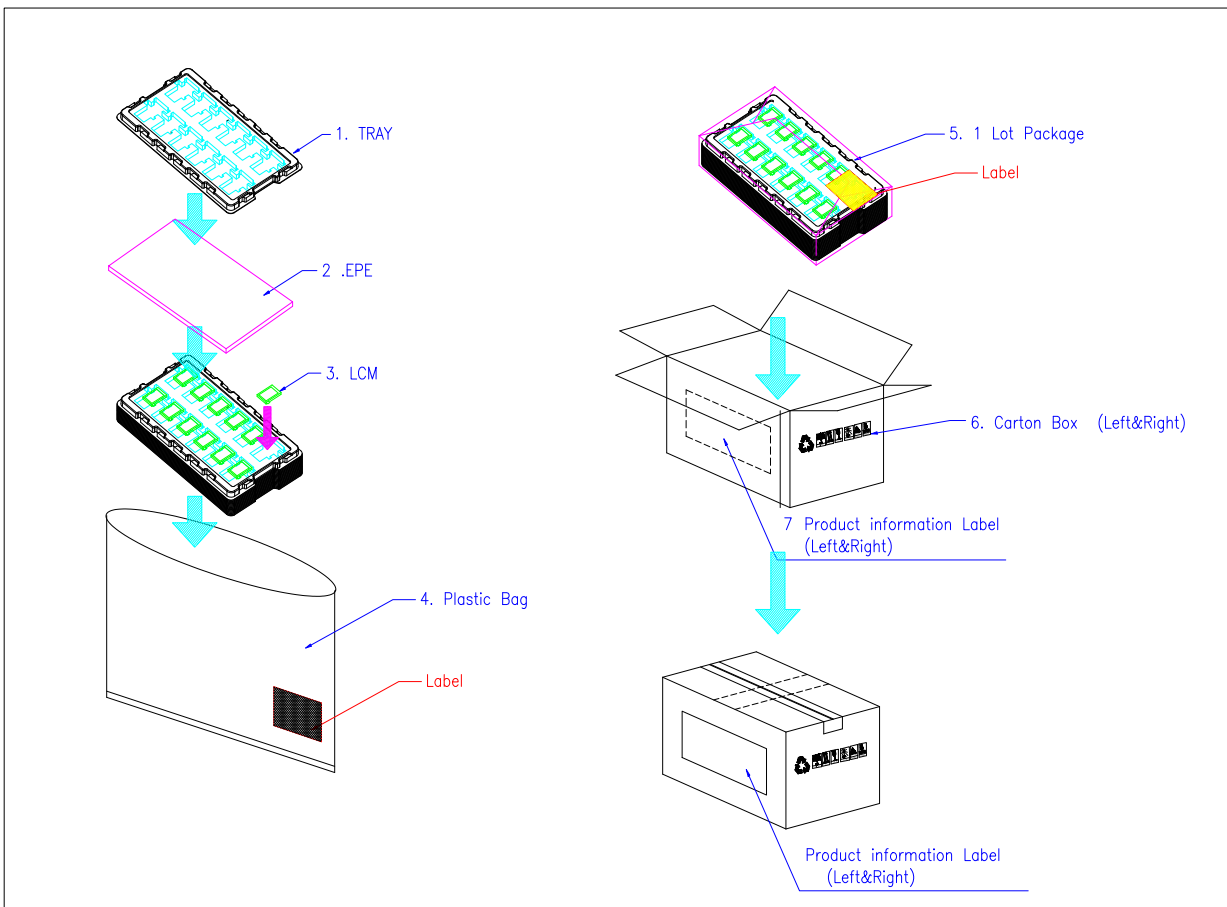

### 11.2 Packing Label

TBD